

MAQ[®] 20

Industrial Data Acquisition & Control System

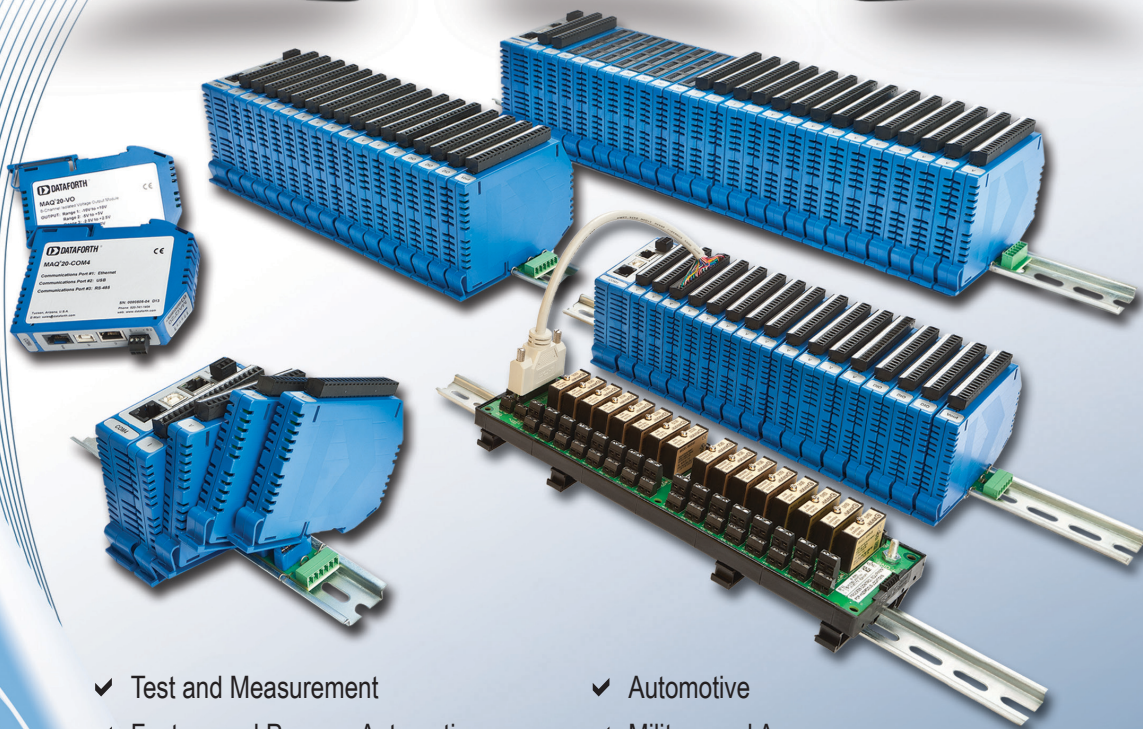

- ✓ Test and Measurement
- ✓ Factory and Process Automation
- ✓ Control and Machine Automation
- ✓ Environmental Monitoring
- ✓ Diagnostic, Repair, and Quality Monitoring
- ✓ Research and Analysis
- ✓ Automotive
- ✓ Military and Aerospace
- ✓ Power and Energy
- ✓ Oil and Gas
- ✓ Semiconductor and Process Equipment



MAQ[®]20 Industrial Data Acquisition & Control System

Encompassing more than 30 years of design excellence in the test and measurement and control industry, the MAQ20 family consists of high performance, DIN rail mounted, programmable, multi-channel, industrially rugged signal conditioning I/O and communications modules.

The modules mount on industry standard 35x7.5mm gull-wing DIN rails. A backbone within the rail provides power and communication interconnections between the communications modules and each I/O module.

The MAQ20 interfaces directly to industrial sensors and transducers. It provides input protection, noise filtering, amplification, CJC and linearization, shunt calibration, and data logging.

Instrument Class[®] Performance

- Industry's Most Affordable Price per Channel
- $\pm 0.035\%$ Accuracy
- Industry Leading $\pm 0.3^\circ\text{C}$ CJC Accuracy Over Full Operating Temperature Range
- 1500Vrms Channel-to-Bus Isolation
- Up to 240Vrms Continuous Field I/O Protection
- 4000V Input Transient Protection
- Wide Range 7-34VDC Power
- -40°C to $+85^\circ\text{C}$ Industrial Operating Temperature
- CE Compliant, UL/CUL Listing and ATEX Compliance Pending

Industry Leading Functionality

- Up to 24 I/O Modules – 384 Analog or 480 Digital Channels – per System, per 19" Rack Width
- Per-Channel Configurable for Range and Alarms
- Load Share Power Supply Modules for Expansion, Standby and Redundant Power
- System Can Operate Remotely Without Host PC Intervention
- System Can Operate as Standalone Data Logger
- System Can Be Accessed Over the Internet from Anywhere

Distributed Processing

- Output Modules Programmable for User-Defined Waveforms
- Discrete I/O Modules Offer 7 High Level Functions:
 - Pulse/Frequency Counter
 - Time Between Events
 - Pulse/Frequency Counter with De-bounce
 - Frequency Generator
 - PWM Generator
 - Waveform Measurement
 - One-Shot Pulse Generator

Intuitive Graphical Control Software, Integral PID Control, Software Tools

- ReDAQ[®] Shape Graphical HMI Design & Runtime Solution
 - Up to 32 PID Loops With Auto-Tune
- IPEmotion Advanced Features & Multi-Language Solution
 - Formulas, Data Logger, TEDS, PID, Scripting
- Software Tools
 - Python API, OPC Server, LabVIEW VIs

Disclaimer: IPEmotion, Python, OPC Server, and Labview are registered trademarks.

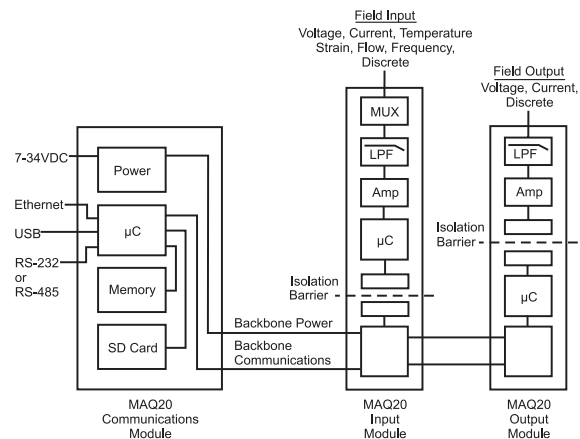

MAQ20 System Block Diagram

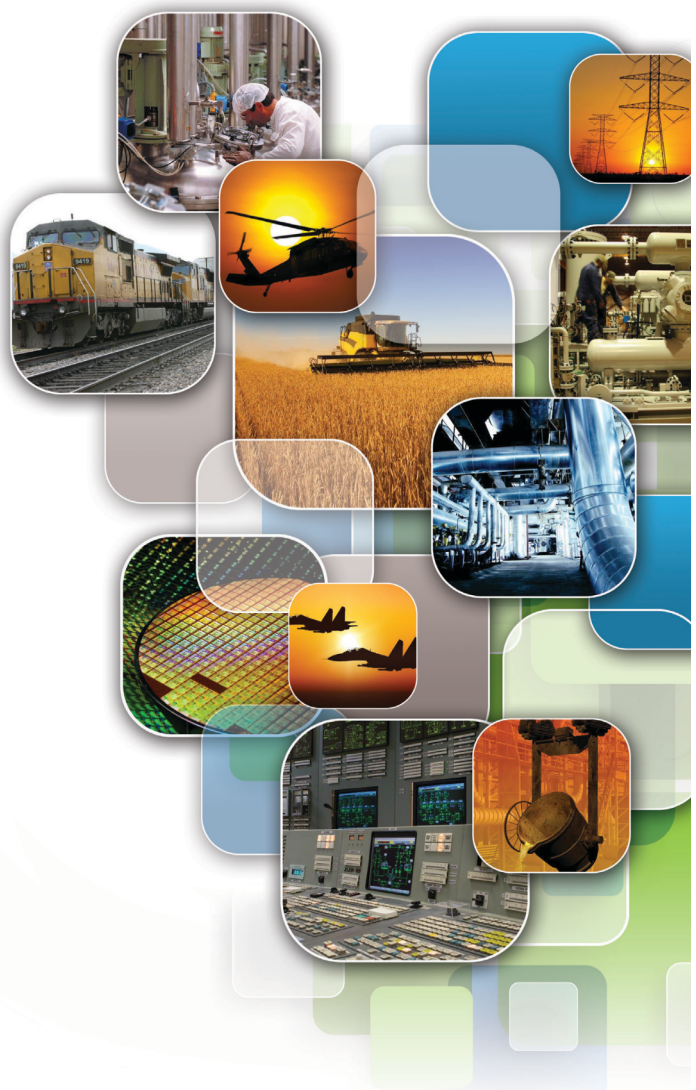

The Modules: Compact, Flexible, Powerful

Communications Modules

- Manage System I/O and Run PID Control
- Communicate to Host Using Ethernet, USB, RS-485, RS-232
- Use Modbus TCP or RTU Protocols
- Interface to up to 24 I/O Modules to Create a 384-Analog Channel or 480-Digital Channel System
- Automatically Register I/O Modules

Analog Input Modules

Process Voltage & Process Current Input Modules

- Interface to Volt, Millivolt, Milliamp Sensors and Equipment
- 8-Channel Differential or 16-Channel Single-Ended Input
- All Channels Individually Configurable for Range, Alarms, Averaging

Isolated Process Voltage & Process Current Input Modules[⊙]

- 8 Input Channels with Multiple Ranges and High Resolution Conversion
- Precise Measurement of Voltage and Current Signals
- All Channels Individually Configurable for Range, Alarms, Averaging, High-Speed Burst Scan
- 300Vrms Channel-to-Channel Isolation

Thermocouple Input Modules

- Interface to Types J, K, T, R and S Sensors
- 8-Channel Differential Input
- All Channels Individually Configurable for Range, Alarms, Averaging

RTD and Potentiometer Input Modules

- Interface to 2-Wire, 3-Wire and 4-Wire Sensors
 - 6 Input Channels for 2-Wire or 3-Wire Sensors
 - 5 Input Channels for 4-Wire Sensors
- Interface to 100Ω Pt, 120Ω Ni RTDs, and up to 5kΩ Potentiometers
- All Channels Individually Configurable for Sensor, Range, Alarms, Averaging

Strain Gage Input Module

- Interface to Full, Half, and Quarter Bridge Sensors
- 4 Input Channels for 4-Wire or 6-Wire Sensors
- All Channels Individually Configurable for Range, Alarms, Averaging
- Burst Mode for Fast Event Capture
- Programmable, Excitation, Shunt Calibration, Remote Sense

Frequency Input Module

- 8 Input Channels
- 50mV Sensitivity
- Input Range 1Hz to 1MHz plus State Change
- All Channels Individually Configurable for Range and Alarms

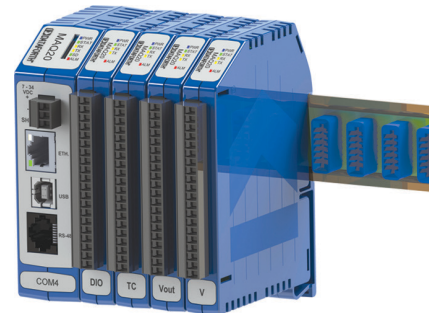

Communications Module with I/O Modules

Analog Output Process Voltage & Process Current Modules

- 8 Isolated Voltage or Current Output Channels
- All Channels Individually Configurable for Range and Programmable Output
- User-Defined Default Output and Output Waveform
- 300Vrms Channel-to-Channel Isolation

Discrete Input/Output Modules

- 4 or 5 Isolated Input and Output Channels
- User-Defined Default Output and Output Waveform
- 7 High Performance Special Functions
- 300Vrms Channel-to-Channel Isolation

High Density Input Modules with or without Compliance Voltage

- Interface to 10-120VDC/VAC Signals (MAQ20-DIV20)
- 24VDC Compliance Voltage for Interface to Devices Requiring Excitation (MAQ20-DIVC20)
- 20 Discrete Input Channels

High Density Isolated Discrete Output Module

- 20 Isolated Discrete Output Channels with User Configurable Default Output States
- Channels Switch up to 60VDC Signals and Sink up to 3A Current
- Channels Switched Individually or in Blocks
- 150Vrms Channel-to-Channel Isolation

Discrete Relay Output Module

- 20 Isolated SPST Latching Relay Output Channels
- Channels Switch Between 2A at 30V and 0.4A at 150V
- Contact State Readback on Each Channel
- Relays Controlled Individually or in Blocks
- 150Vrms Channel-to-Channel Isolation

All MAQ20 I/O Modules

- 1500Vrms Field-to-Bus Isolation
- Each Channel Protected up to 240Vrms Continuous Overload
- Overload and Reverse Protection on Power Input Terminals
- -40°C to +85°C Industrial Operating Temperature
- Designed for Installation in Class I, Division 2 Hazardous Locations

[⊙]Preliminary at date of printing. Contact factory for availability.

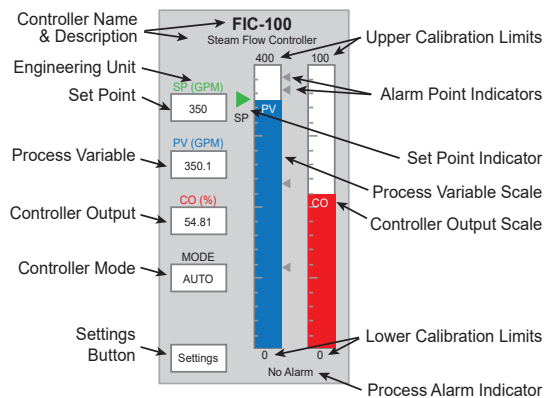

PID Faceplate in ReDAQ Shape Software

Leading-Edge PID Loop Control

- Integral in Both ReDAQ Shape for MAQ20 and IPEmotion Software
- Up to 32 PID Control Loops with ReDAQ Shape for MAQ20
 - Controller Runs in Real Time
 - Controller Accessed through Faceplates
- Unlimited PID Control Loops with IPEmotion
 - Controller Runs in Windows
- Typical PID Applications
 - Steam, Water, and Chemical Flow Control
 - Tank Level Control
 - Heat-Exchanger / Reactor Temperature Control
 - Pressure Control

ReDAQ® Shape Software for MAQ20

- One-Time Low-Cost License Fee
- Ideal for Data Acquisition, Monitoring and Control Applications
- 3 Easy Steps to Create Customized Applications
- 65 Toolbox Tools Simplify Project Creation
- No Setup Required to Acquire and Analyze Data
- Create, Save, Open GUI Projects for Test, Process, Data Collection, Data Analysis
- Supports Any Graphical File Format
- Most Efficient Way to Configure and Run MAQ20 Systems



IPEmotion Software for MAQ20

- Advanced, Intuitive Data Acquisition / Test & Measurement Software
- Automatic Recognition of Connected Devices
- Automatic Configuration of All Channels
- Automatic Start of Measuring
- Instant Visualization of All Measurement Values
- Live Data Display, Recording, Online and Offline Math and Logic Functions
- Live Adjustment
 - Analyze and Verify Measurements During Active Data Acquisition
 - GUI Adaptation During Active Measurement and Storage
- Post Processing and Report Generation
- Easy Drag and Drop HMI Creation
- High Speed Recording to 1000 Samples/s
- Communication with MAQ20 via Plug-In Driver
- Import and Export Recorded Data Using Standard File Formats
- Scripting Option with VB or Python Software
- Available in 7 Languages
 - English, German, French, Italian, Chinese, Korean, Japanese

Software Tools

- Python API
 - Object Oriented Programming
- OPC Server
 - Interface to SCADA, HMI, or Custom Software
- LabVIEW VIs
 - Simplified Communication in LabVIEW Environment

