

Features

- 15.6" New Generation Stainless Steel Panel PC
- Intel Celeron J6412 Processors
- True Flat Front Bezel Design and Grade 304 Stainless Steel Enclosure (Grade 316 for Option)
- IP66/IP69K Rated with M12 Connectors
- Ultra Slim Front Frame Design
- Special Hygienic Bolts on Rear Case
- Waterproof Wireless Antenna Covers to Solve the Bend Damage and Easy to Clean
- Support Ergonomic Versatile Mounting:
VESA Mount 100 x 100 / Floor Stand / Swing ARM

Specifications

System	
CPU	Intel Celeron J6412 (2.0GHz) Processor
System Chipset	SoC
Memory	1 x 260-pin SO-DIMM up to 32GB DDR4 3200MHz
TPM	TPM 2.0

IO Port	
USB	1 x M12 8-pin for 2 x USB 2.0 with waterproof cover
Serial / Parallel	1 x M12 8-pin COM1, RS-232/422/485, default RS-232, with waterproof cover
LAN	1 x M12 8-pin for LAN with waterproof cover
Power Connector	1 x M12 3-pin for DC power with waterproof cover 1 x Power switch on the rear
Option	2 x optional blank M12 connector with waterproof cover for selecting two from the following options: 2 x USB 2.0 1 x USB 3.2 Gen.1 1 x HDMI 1 x LAN 1 x COM

Storage Space	
M.2	1 x M.2 B-Key 2242/2280 for SSD (SATA3)

Expansion	
Expansion slot	1 x Full-size mini PCIe slot for 4G/5G 1 x Micro SIM slot 1 x M.2 E-Key 2230 for WiFi/BT module
RFID module	RFID module design on the front side (for option)

Display	Standard		High Brightness Optional	
	15.6" TFT-LCD		15.6" TFT-LCD	
Display Type	default	optional	default	optional
Max. Resolution	1366 x 768	1920 x 1080	1366 x 768	1920 x 1080
Max. Color	16.7M	16.7M	16.7M	16.7M
Luminance (cd/m ²)	400	500	1000	1000
View Angle	170(H)/160(V)	178(H)/178(V)	160(H)/160(V)	170(H)/170(V)
Contrast	500:1	1000:1	500:1	1000:1
Backlight Lifetime	50,000 hrs	50,000 hrs	50,000 hrs	50,000 hrs

Touch Screen	
Type	Projected Capacitive Touch
Interface	USB
Light Transmission(%)	90%

Dimensions

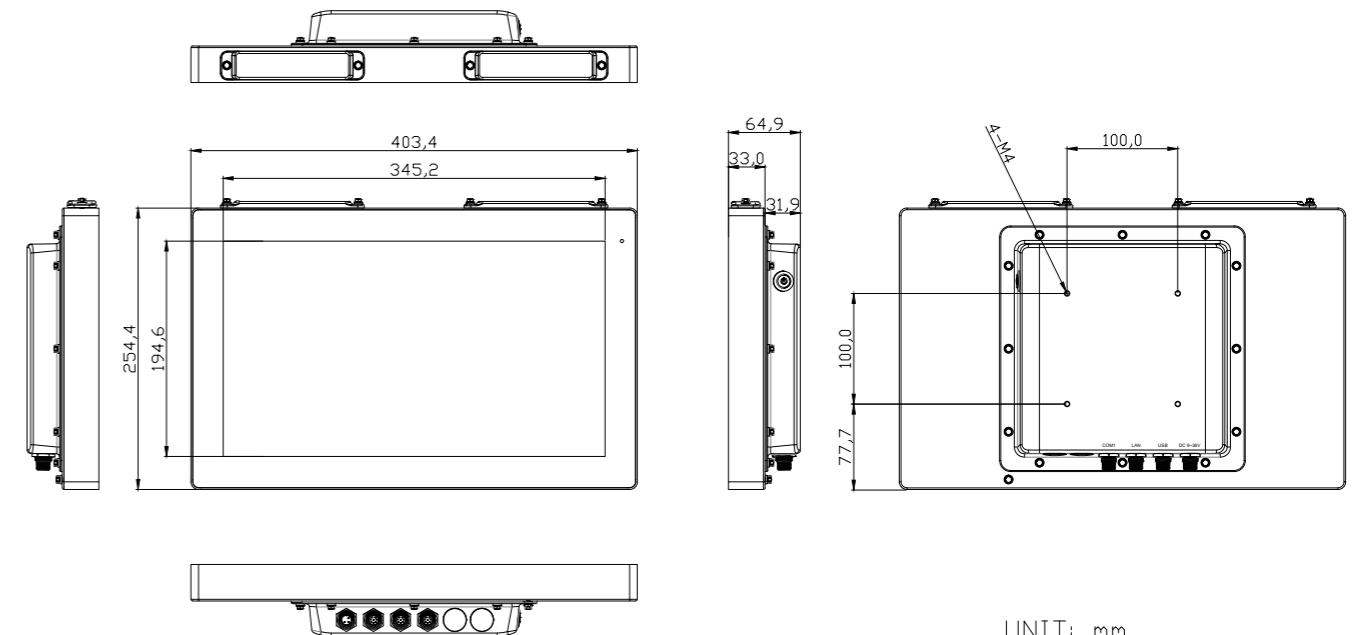

UNIT: mm
Tolerance: +0.5

Power	
Power Input	DC 9~36V
Power Consumption	PhanTAM-816BPH: 35W

Mechanical	
Construction	304 Stainless Steel Chassis (default), 316 Stainless Steel Chassis (optional)
Mounting	VESA Mount 100 x 100, Floor Stand / Swing ARM (optional)
IP Rating	Total IP66/IP69K
Dimensions	404.4 x 225.4 x 64.9 mm
Net Weight	5 kg

Environmental	
Operating Temperature	0~50°C (WT1: -20~60°C for optional)
Storage Temperature	-30~70°C
Humidity	10 to 90% @ 40°C, non-condensing
Certificate	CE/FCC Class A

Operating System Support	
Windows 10 IoT ENT LTSB, Windows 11	

Ordering Information	
PhanTAM-816BP	15.6" WXGA IP66/IP69K stainless steel panel pc, Intel Celeron J6412 Processors, 1 x SO-DIMM DDR4 slots, 128GB TLC SSD, projected capacitive touch, 9~36V DC power input with Adapter
PhanTAM-816BPH	15.6" WXGA IP66/IP69K stainless steel panel pc, Intel Celeron J6412 Processors, 1 x SO-DIMM DDR4 slots, 128GB TLC SSD, projected capacitive touch, 9~36V DC power input with Adapter, 1000 nits