

DMM-32DX-AT

Analog I/O PC/104 Module

With Advanced Automatic-Autocalibration

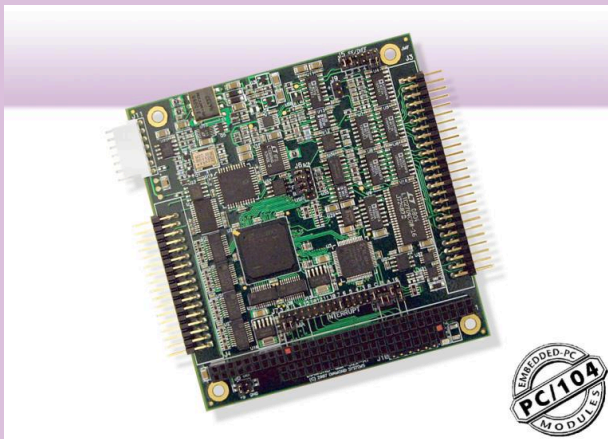

Highly Advanced Analog I/O Board

The Diamond-MM-32DX-AT includes a comprehensive suite of analog and digital features to fit a wide variety of embedded application needs.

Unparalleled Analog Accuracy

Using patented automatic-autocalibration technology, DMM-32DX-AT provides accurate analog measurements across its entire rated operating temperature range, ensuring reliable performance for critical applications.

Rugged Design

Extended temperature operation of -40°C to +85°C is tested and guaranteed. The DMM-32DX-AT uses ceramic capacitors for durability in high altitudes or other harsh environments.

Shortened Development Time

Diamond's advanced Universal Driver software is included free and provides a programming library that simplifies control of the board's features and enables you to develop your application software quickly.

- ◆ 32 analog inputs, 16-bit resolution
- ◆ Patented auto-autocalibration for high accuracy
- ◆ 250KHz maximum sampling rate
- ◆ Interrupt based A/D data transfer with FIFO support
- ◆ 4 analog outputs, 16-bit resolution
- ◆ 24 programmable direction digital I/O lines
- ◆ Counter / timers for A/D control and general use
- ◆ Low noise design
- ◆ Extremely rugged -40°C to +85°C (-40°F to +185°F) operating temperature
- ◆ Free Universal Driver software

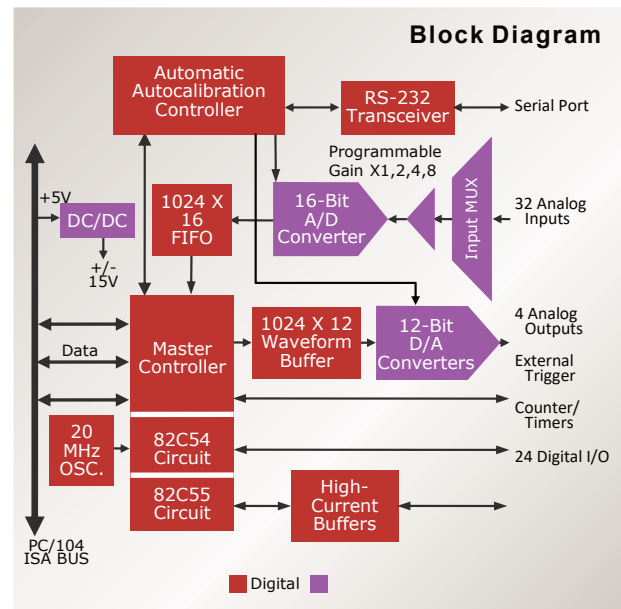

DMM-32DX-AT: Analog I/O PC/104 Module



Specifications	
ANALOG INPUTS	
Number of inputs	32 single-ended or 16 differential, user selectable
A/D resolution	16 bits
Input ranges	±10V, ±5V, ±2.5V, ±1.25V, ±0.625V, 0-10V, 0-5V, 0-2.5V, 0-1.25V, 0-0.625V programmable
Max sample rate	250KHz
Protection	±35V on any analog input without damage
Nonlinearity	±3LSB, no missing codes
On-board FIFO	1024 samples, programmable threshold
A/D and D/A calibration	Autocalibration with software support
ANALOG OUTPUTS	
Number of outputs	4, 12-bit resolution
Output ranges	±2.5V, ±5V, ±10V, 0-5V, 0-10V
Output current	±5mA max per channel
Settling time	6µS max to 0.01%
Relative accuracy	±1 LSB
Nonlinearity	±1 LSB, monotonic
DIGITAL I/O	
Number of I/O	24 lines
Input voltage	Logic 0: 0.0V min, 0.8V max Logic 1: 2.0V min, 5.0V max
Input current	±1µA max
Output voltage	Logic 0: 0.0V min, 0.33V max Logic 1: 2.4V min, 5.0V max
Output current	Logic 0: 15mA max per line Logic 1: -84mA max per line
COUNTER/ TIMERS	
A/D Pacer clock	32-bit down counter
Clock source	10MHz on-board clock or external signal
General purpose	16-bit down counter
MISCELLANEOUS	
Power supply	+5VDC ±10% at 410mA
Operating temp	-40°C to +85°C (-40°F to +185°F)
Weight	3.4oz (96g)
MTBF	972,275 hours at +20°C
RoHS	Compliant

Software Support

Diamond's Universal Driver software provides a high-level programming library for all of Diamond's data acquisition products. All data acquisition features are supported with easy-to-use function calls, resulting in a reduced learning curve and shortened application development time. Universal Driver works with Windows XP, CE, Linux, QNX and DOS. Application examples are included for each function and OS to provide a quick starting point for development.

Key Features

The DMM-32DX-AT features 32 A/D input channels with high-accuracy 16-bit resolution, 250KHz maximum sampling rate, programmable input ranges, and user-selectable single-ended / differential configuration.

The four D/A 16-bit output channels feature user-selectable output ranges as well as a programmable waveform generator feature.

DMM-32DX-AT's 24 digital I/O lines feature direction programmability in 8-bit ports as well as buffers for enhanced output current of -15mA (Logic 1) / 64mA (Logic 0). All DIO lines feature jumper-selectable pull-up / pull-down resistors as well as ESD protection devices to help prevent field failures.

On-board programmable counter/timer circuitry includes a 32-bit counter/timer for A/D and D/A sample timing, as well as a 16-bit counter/timer for general counting, timing, and programmable interrupt functions.

Automatic-Autocalibration for Best Accuracy

Diamond's top-performing automatic-autocalibration circuitry enables you to calibrate the analog circuits under software control at any time, maintaining best accuracy under all conditions. An on-board micro-controller manages the autocalibration operation automatically for extreme accuracy and ease of operation. Temperature- and time-dependent measurement drift is eliminated, as the board can be calibrated as often as desired in just a few seconds to ensure accurate reading in all environments.

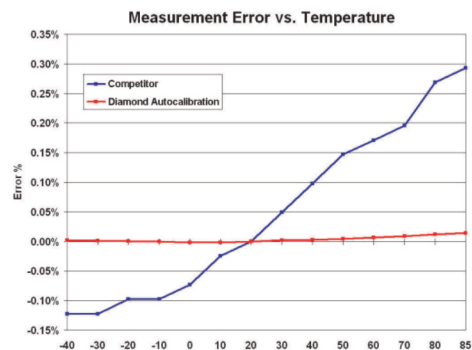

Ordering Information

DMM-32DX-AT Analog I/O PC/104 Module with auto-autocalibration