



Floyd model BB01 with Nano module installed



Floyd model BB01 with fan sink

FEATURES

- 1 or 2 gigabit Ethernet ports
- Optional PoE+ support (with external power source)
- 2 HDMI 2.0a/b ports
- 1 USB 3.0 port with type A connector
- 2 USB 2.0 ports with type A connector; 1 port can serve as OTG
- 8 GPIO with 3.3V logic levels
- 2 serial ports with RS-232/422/485 (depending on model)
- 3 dual/quad lane MIPI/CSI camera ports
- 1 CAN port (NX module only)
- 1 Mini PCIe socket with PCIe and USB support
- 1 M.2 2280 PCIe x1 or x4 NVME socket
- Size: 5.8 x 3.0" / 147 x 76mm
- Input voltage: 12-24VDC
- 25 to +80°C operating temperature (same as Jetson Nano / NX)

The FLOYD carrier board converts the Nvidia Jetson Nano and Xavier NX modules into complete embedded systems by providing interface circuitry, I/O connectors for all module features, camera interfaces, power supply, and additional I/O. Camera inputs include 2 PoE Gigabit Ethernet ports, 3 MIPI/CSI 2/4-lane connectors, and 1 USB 3.0 port. MiniCard, M.2, and Micro SD sockets support I/O expansion and storage. FLOYD + NVIDIA redefine possibility; the combination of Nvidia's performance/power efficiency and Diamond's I/O enables a new generation of high-compute, low-cost solutions.

Floyd's multiple camera inputs provide increased versatility for use in a wide variety of imaging applications, which make up a substantial portion all Jetson applications today. As with all Diamond products, Floyd is designed and built for reliable performance and extended operating temperature to meet the full capabilities of the Jetson modules.

With the Xavier NX module installed, Floyd offers 1 CAN 2.0B port. The standard configuration is non-isolated; isolation is available as special order.

Floyd is supported by a full Linux BSP based on Nvidia Jetpack. This software is available as a free download from our support area.

◆ Carrier Board Configurations

Floyd is available in two configurations: FLD-BB01 offers the complete suite of I/O features, while FLD-BB02 targets lower-cost applications requiring less I/O. The BB02 model also omits the PCIe switch needed for the BB01 additional I/O, thereby enabling a full PCIe x4 link to the M.2 socket for potentially higher flash memory read/write speeds.

Feature	FLD-BB01	FLD-BB02
Gigabit Ethernet	2	1
PoE	Both ports	No
HDMI	2	1
Camera CSI 4-lane	3	3
USB 3.0	1	1
USB 2.0	2	2
M.2 2280 socket	PCIe x1	PCIe x4
Minicard socket	Full size PCIe	No
SD card	Yes	Yes
GPIO 3.3V	8	8
Serial	2x RS-232/422/485	1x RS-232 1x RS-232/485
CAN 2.0	1 (NX only)	No

◆ FLOYD Block Diagrams

FLOYD FLD-BB01 Block Diagram

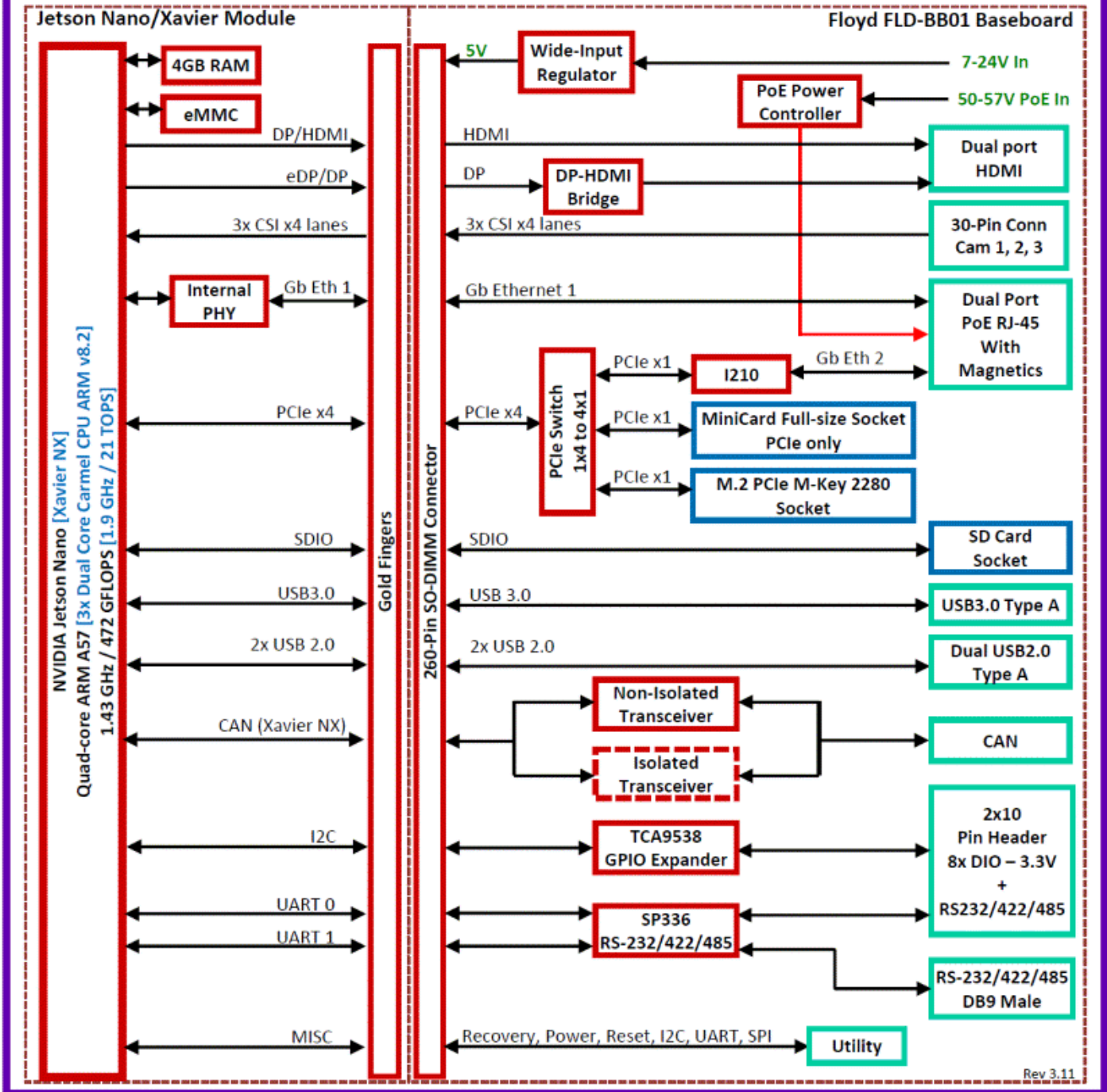

FLOYD FLD-BB02 Block Diagram

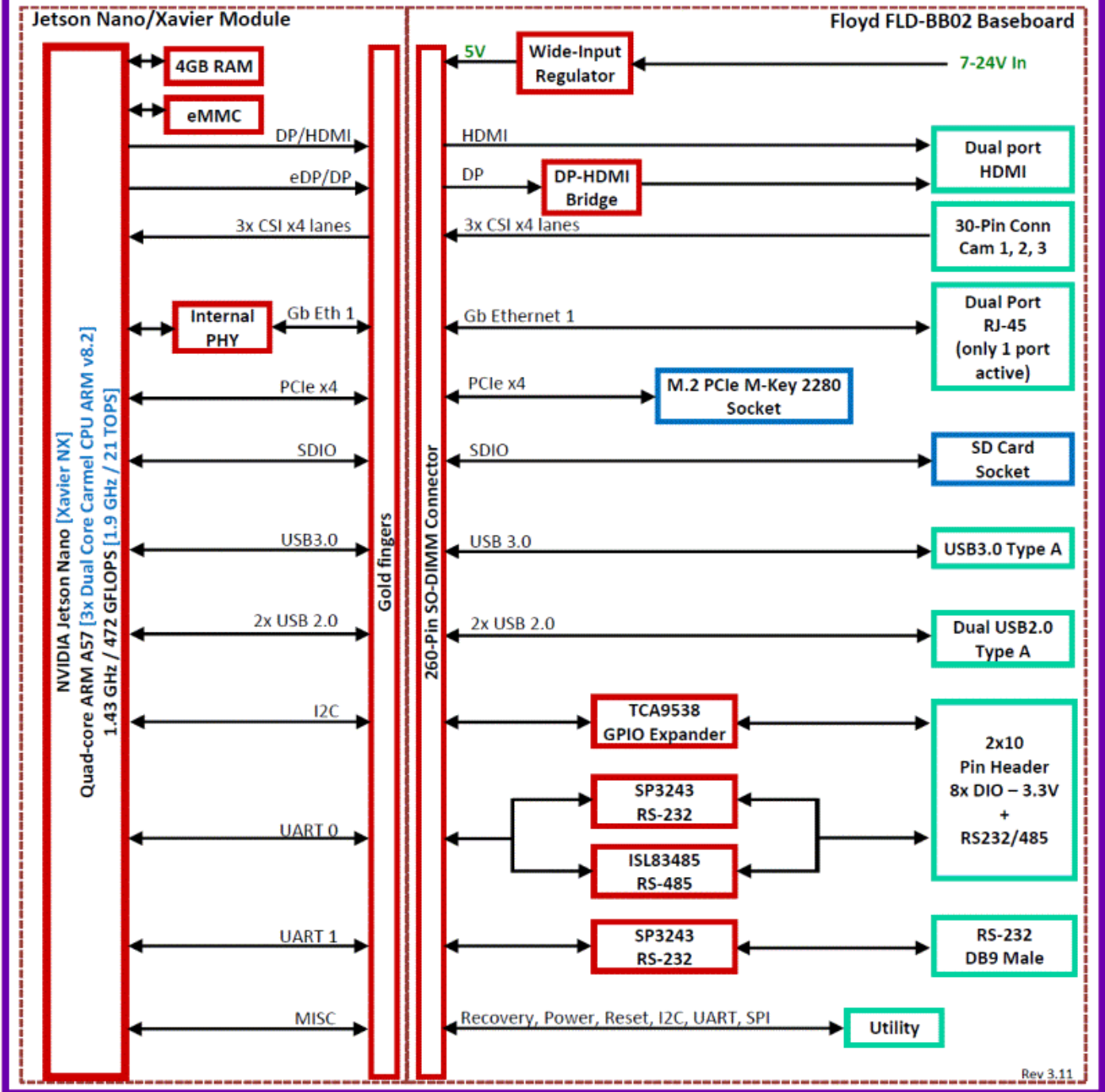

◆ Floyd Features

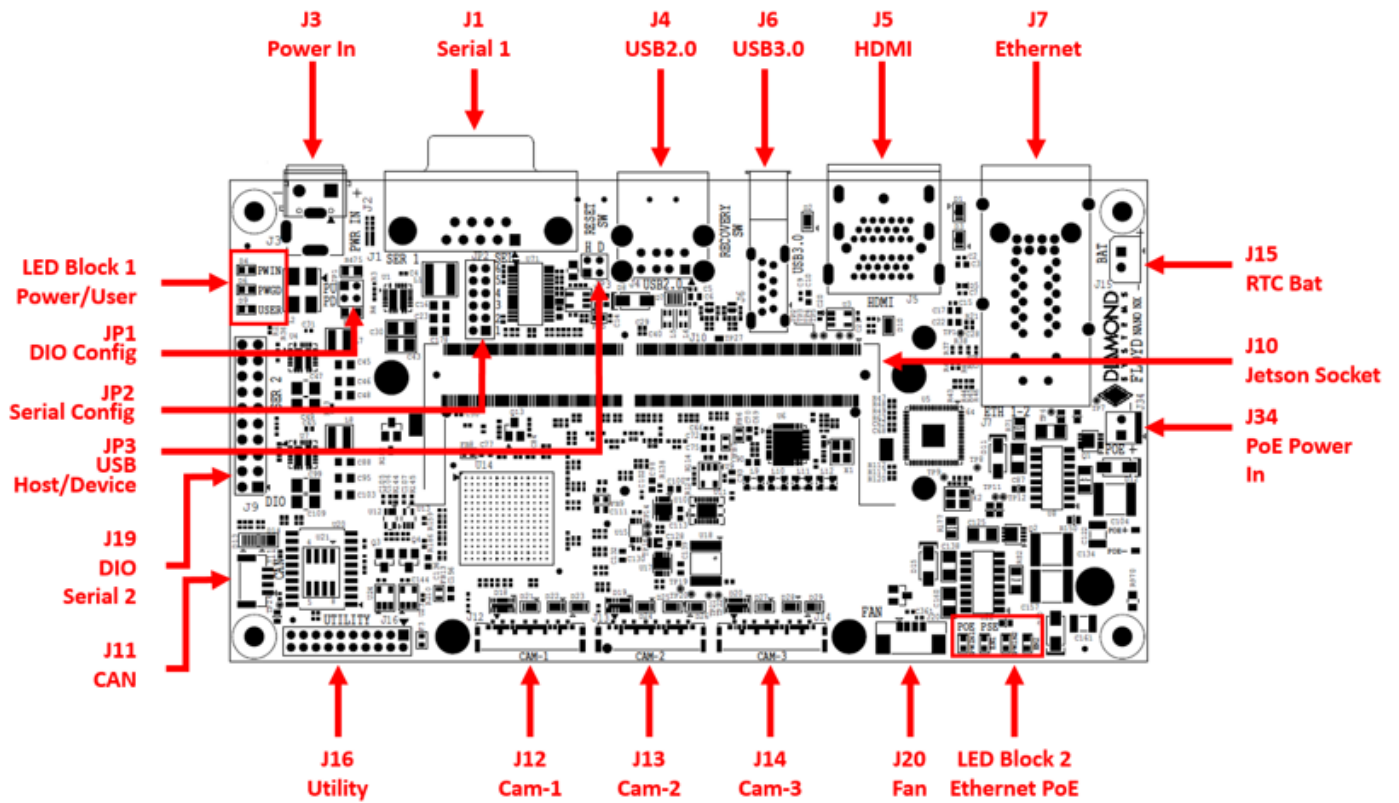

Note: Mini PCIe and M.2 2280 sockets are located on the bottom side.

◆ Cables

Several accessory cables are available for use with Floyd. The different models and Jetson modules require different cables depending on which features are available or in use in the application.

Cable	Description	Drawing
6980524	External battery cable, discrete wires	Show
6981016	High-power input cable, 2 conductors For FLD-BB01 only	Show
6981164	Cable, IDC20F to IDC20F, 2mm pitch, 12" length	Show
6981182	CANbus 2.0 cable, JST 1x4 to DB9M For FLD-BB01 with Xavier NX module only	Show
C-DB9M-2	Serial port cable, 2x DB9M to 2x10 .1" socket For GPIO and 2nd serial port	Show

◆ Product Configurations

◆ Product Configurations

Floyd is available in four levels of integration to fit any project requirements:

Carrier board	We provide just the carrier board. You provide the Nvidia module and packaging solution. You program the Linux OS into the module. Optional heat sink and fan sink accessories are available, see Accessories at the bottom of this page.
Carrier board with Jetson module installed	We install the selected Jetson module (Nano, NX, TX2 NX) and load the Linux operating system. Heat sink / fan sink accessories are available. You provide the packaging solution.
System kit	We provide the carrier board and the complete packaging solution. You supply and install the Jetson module, program the OS, and assemble the system.
Complete system	We provide the carrier board with jetson module installed and programmed, fully assembled in the JetBox enclosure, including an AC adapter, ready for operation.

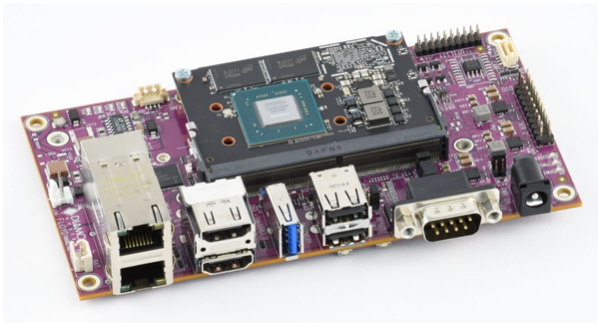

Ordering Information

Models and Accessories

FLOYD

available models:

FLD-BB01	Floyd carrier, full feature with PoE	Available
FLD-BB02	Floyd carrier, low cost configuration	Available
FLD-NAO-FS-01	Floyd subassembly, BB01 carrier board with Nano module installed and programmed, with fan sink	Available
FLD-NAO-FS-02	Floyd subassembly, BB02 carrier board with Nano module installed and programmed, with fan sink	Available
FLD-XNX-FS-01	Floyd subassembly, BB01 carrier board with NX module installed and programmed, with fan sink	Available
FLD-XNX-FS-02	Floyd subassembly, BB02 carrier board with NX module installed and programmed, with fan sink	Available

Please [login](#) or [signup](#) for an online quote request.

Cables and accessories

available models:

6882601	Floyd fan sink, 100x50mm
6882604	Floyd heat sink, 100x50mm
6980524	External battery cable, discrete wires
6981016	High-power input cable, 2 conductors For FLD-BB01 only
6981164	Cable, IDC20F to IDC20F, 2mm pitch, 12" length
6981182	CANbus 2.0 cable, JST 1x4 to DB9M For FLD-BB01 with Xavier NX module only
C-DB9M-2	Serial port cable, 2x DB9M to 2x10 .1" socket For GPIO and 2nd serial port

Please [login](#) or [signup](#) for an online quote request.

www.diamondsystems.com | [Sunnyvale, California USA](#) | [+1-650-810-2500](tel:+16508102500) | sales@diamondsystems.com