

**FLOYD-SC Compact Expandable Carrier Board for Nvidia Jetson
Nano / NX / TX2 NX GPU Modules**

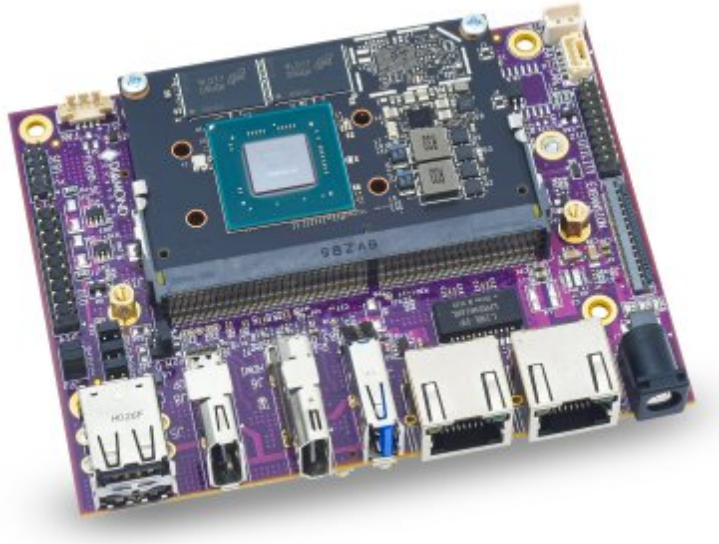

Floyd SC BB02 with Jetson Nano module installed

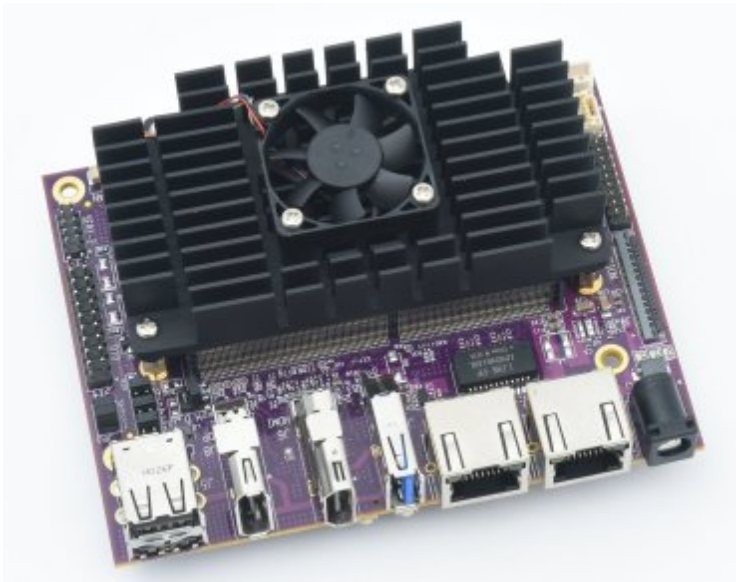

Complete system with module and fan sink

FEATURES

- Supports all I/O features of Jetson Nano / Xavier NX / TX2 NX modules
- Compact size 4.3x3.3" / 110x85mm
- Single/dual gigabit Ethernet
- 1x USB 3.1, 2x USB 2.0
- HDMI + DisplayPort
- 3x CSI dual lane camera inputs
- 2x serial ports: 1 RS-232 and 1 RS-232/485
- 16 GPIO with 3.3V / 5V compatibility
- 1 CAN port (with NX module)
- M.2 2242/2280 M-Key NVMe flash socket
- Heat sink / fan sink cooling (orderable options)
- Expansion connector for use with standard and custom I/O expansion modules
- 7-24VDC power input
- Supports full temperature range of installed Jetson modules, -25 to +80°C
- Available as carrier board, subassembly with installed Jetson module and software, or complete system



Front view, BB02 model

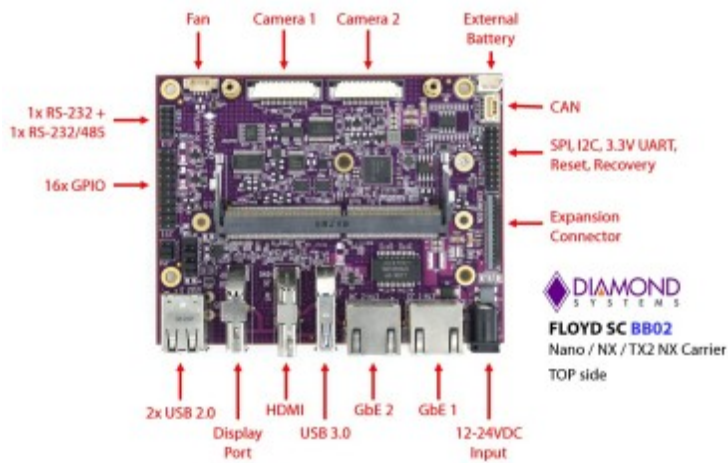

Features, BB02 top side

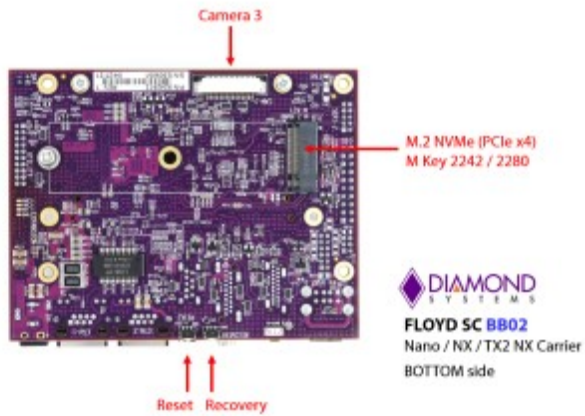

Features, BB02 bottom side

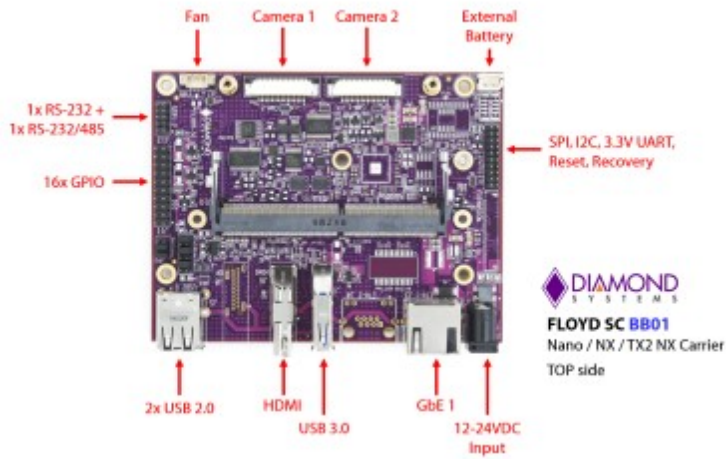

Features, BB01 top side

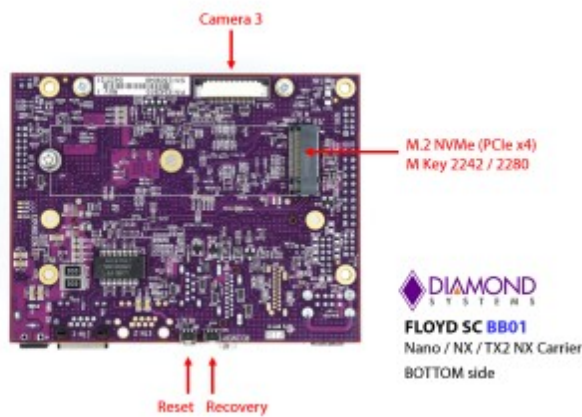

Features, BB01 bottom side

The **FLOYD SC** compact carrier board converts the Nvidia Jetson Nano / TX2 NX / Xavier NX modules into complete embedded systems by providing interface circuitry, I/O connectors for all module features, camera interfaces, power supply, and additional I/O in a solution measuring only 4.3x3.3in² / 110x85mm. A novel expansion I/O connector enables connection of standard and custom daughterboards with additional I/O functionality to simplify the development of customized Jetson solutions.

Floyd SC features up to 3 CSI camera inputs, 2 Gigabit Ethernet ports, 2 USB 2.0 ports, 1 USB 3.0 port, 1 RS-232 and 1 RS-232/485 serial port, 16 GPIO, and HDMI + DP display support. With the NX module installed a second Ethernet port and a CAN port are available. An M.2 M-Key NVME socket supports both 2242 and 2280 size I/O and flash storage modules. Wide voltage input 7-24V provides adaptability to a range of power supplies.

Floyd SC is available in two configurations: a low-cost model with reduced features for Nano and a full-featured model with complete features supporting NX and TX2 NX.

Floyd SC is supported by a full Linux BSP based on Nvidia's Jetpack. This software is available as a free download from our support area.

Floyd SC is available as both a carrier board component and as an assembled subsystem including the selected Jetson module with Linux OS installed. Both heat sink and fan sink cooling options are available.

◆ Product Configurations

Floyd SC is available in a cost-optimized configuration for the Nano module and a full-featured configuration for the TX2-NX and NX modules. The full-featured model can also work with the Nano, however some features are unavailable due to not being present on the module.

Feature	FLDSC-BB01	FLDSC-BB02
Modules supported	Nano	Nano, TX2 NX, NX
Gigabit Ethernet	1	2 (with NX)
USB 3.0	1	1
USB 2.0	2	2
Serial ports	1 RS-232 + 1 RS-232/485	1 RS-232 + 1 RS-232/485
CAN	N/A	1 port 2.0b (with NX)
Display	1 HDMI	1 HDMI + 1 DP
Camera	3x 2-lane CSI Interface	3x 2-lane CSI Interface
Storage / Expansion socket	M.2 M-Key 2242 / 2280 dual footprint	M.2 M-Key 2242 / 2280 dual footprint
Daughterboard expansion	N/A	40-pin connector with PCIe + USB 3.0 connectivity to host module (NX only)

◆ Block Diagrams

FLOYD-SC-BB01 Block Diagram

Rev 1.8

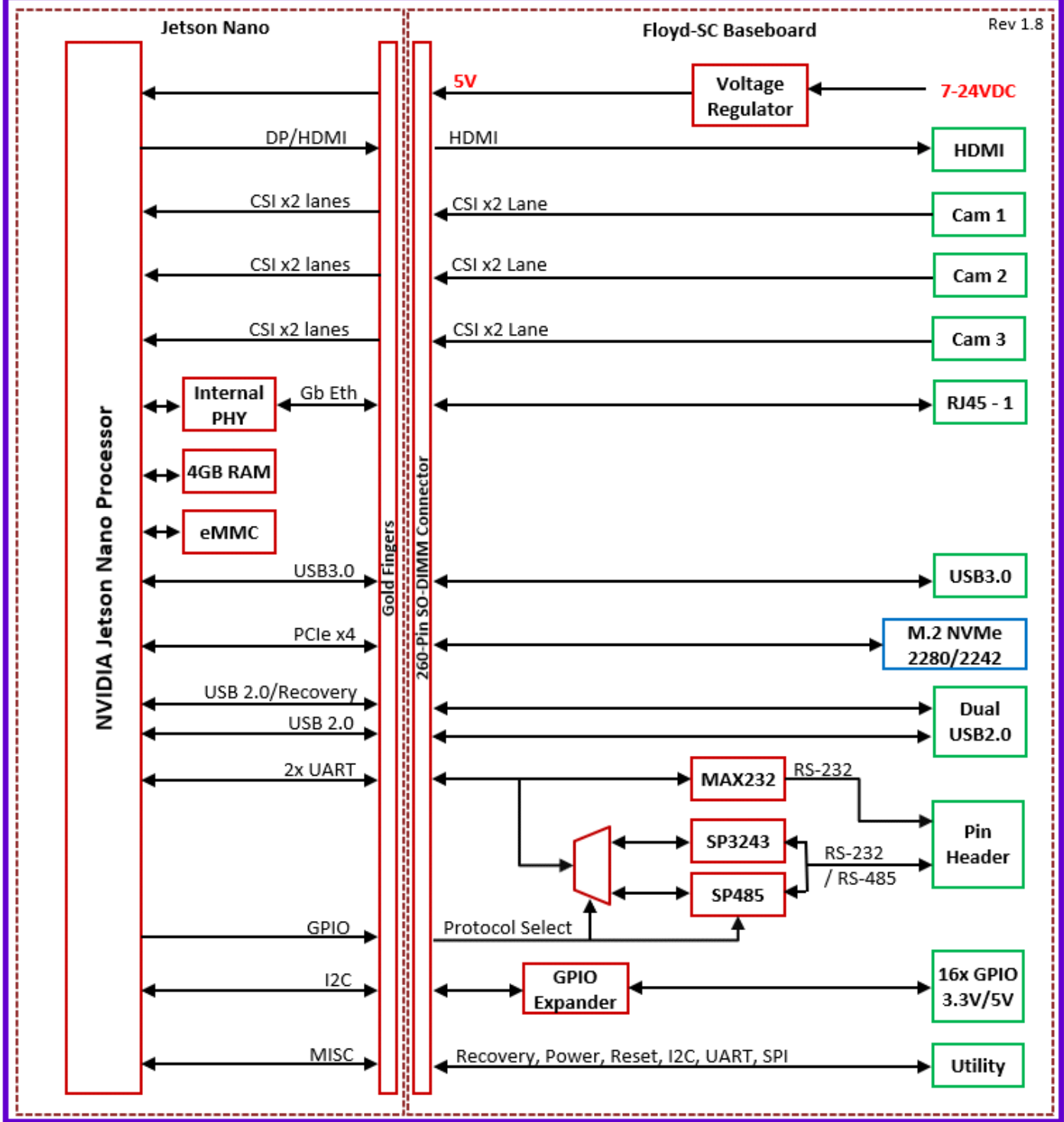

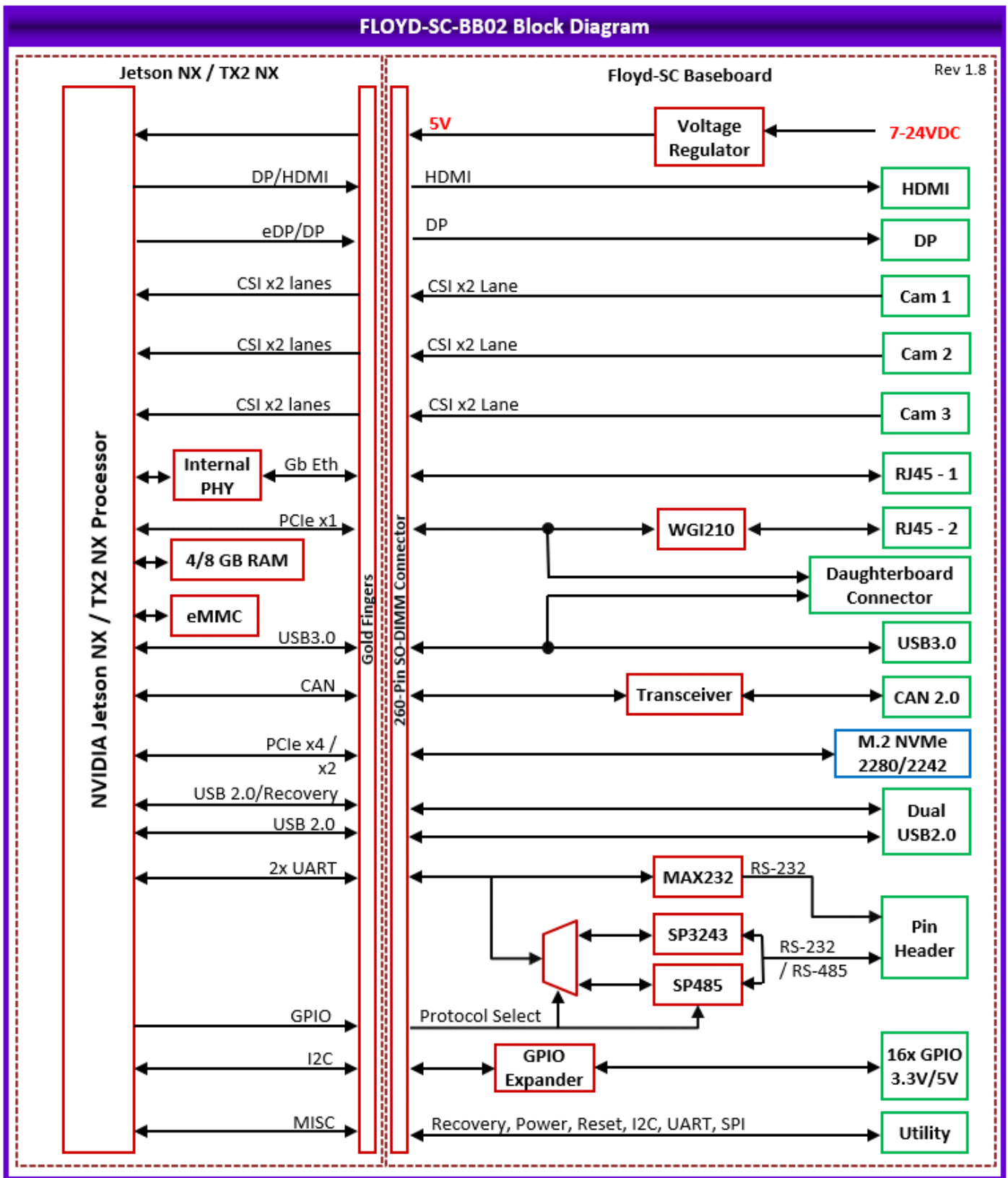

◆ I/O Expansion Connector

A flex cable connector on model BB02 enables additional I/O expansion with off the shelf or custom-developed daughterboards. The connector offers USB 3.0 and PCIe connectivity to the Jetson module, as well as power. Because an I/O daughterboard is much quicker and easier to design than a full-custom carrier board, Floyd SC makes it easy to design customized Jetson solutions with additional I/O. For example, additional USB 3.0 ports, additional Ethernet ports, an Ethernet switch, or even a PoE PD circuit can all easily be implemented on a daughterboard and directly connected to the Jetson module using a native high-speed I/O interface. Daughterboards typically are the same size as the main board and mount directly underneath the main board for convenient packaging.



Side by side mounting provides flexibility for system integration.

◆ Subassembly Options

Floyd SC is available as a complete computing board-level subsystem with Jetson module, heat sink, and Linux OS installed. These subsystems save time by eliminating the assembly, programming, and testing effort.

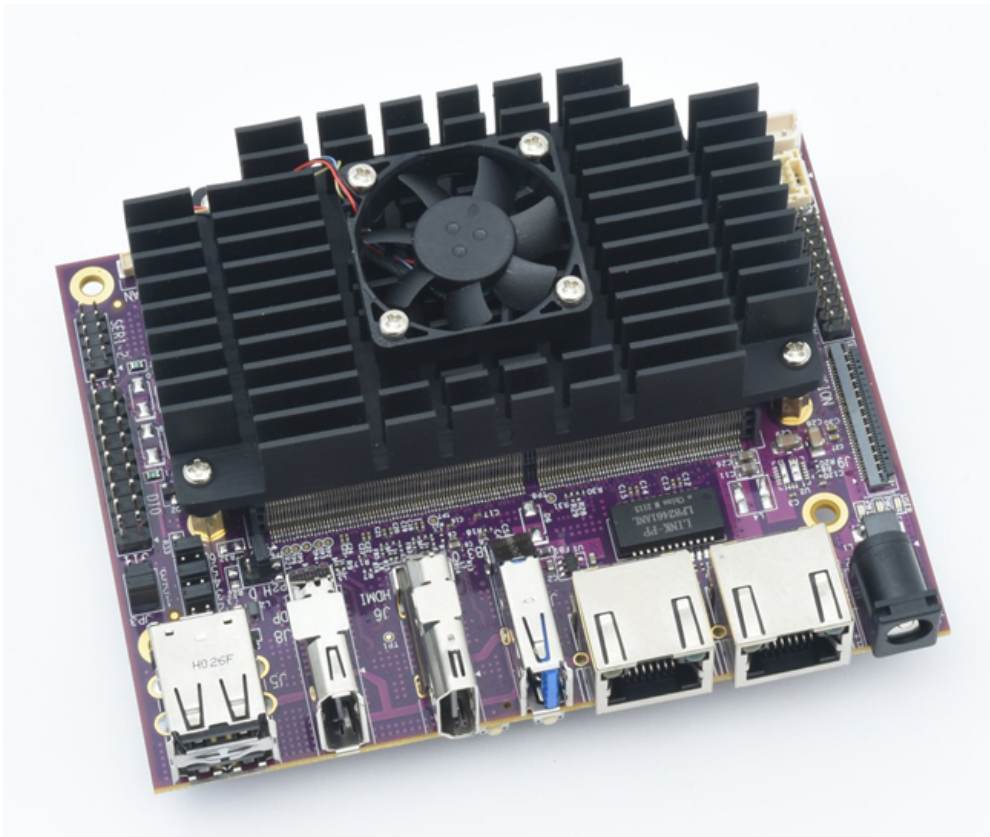

Model Baseboard Jetson Module

FLDSC-ASY-01-NAO BB01 - Basic Nano
 FLDSC-ASY-02-XNX BB02 - Full Xavier NX
 FLDSC-ASY-02-TNX BB02 - Full TX2 NX

◆ Complete Systems

Floyd SC is available as a JetBox system with Jetson module and Linux OS installed, ready to load your application and deploy. All main board I/O, including the I/O on the pin headers, is brought out to the front panel using familiar commercial connectors.



◆ Cables

Most Floyd I/O other than the camera inputs is available using commercial connectors located along the front edge of the board. This arrangement simplifies the design of enclosures. The second serial port, GPIO signals, and CAN port (available with NX module only) do require cables.

All front-facing I/O cables for Floyd SC are industry standard, including Ethernet, HDMI, DisplayPort, and USB. Camera interface cables are generally included with the camera. Other I/O connections require custom cables. A cable kit is available with these custom cables:

Slide Id CBLA not found

CK-FLDSC-01 includes the following cables:

No.	Qty	Cable	Description	Drawing
1	1	6980524	External battery cable, discrete wires	Show
2	1	6981075	Dual serial port DB9M	Show
3	1	6981164	Cable, IDC20F to IDC20F, 2mm pitch, 12" length	Show
4	1	6981182	CANbus 2.0 cable, JST 1x4 to DB9M	Show
5	1	C-20-18	20-conductor ribbon cable, 2x10 .1" IDC sockets	Show

For convenient access to the GPIO and utility signals during development, a screw terminal board is available from third party suppliers. A typical example is [here](#)

◆ Heat Sink

The Jetson modules can consume significant power under heavy load and require cooling. Diamond Systems offers a passive heat sink and active fan sink specifically designed for use on Floyd SC. The fan on the fan sink is controlled automatically by the Linux OS and also by a DSC-supplied utility program.

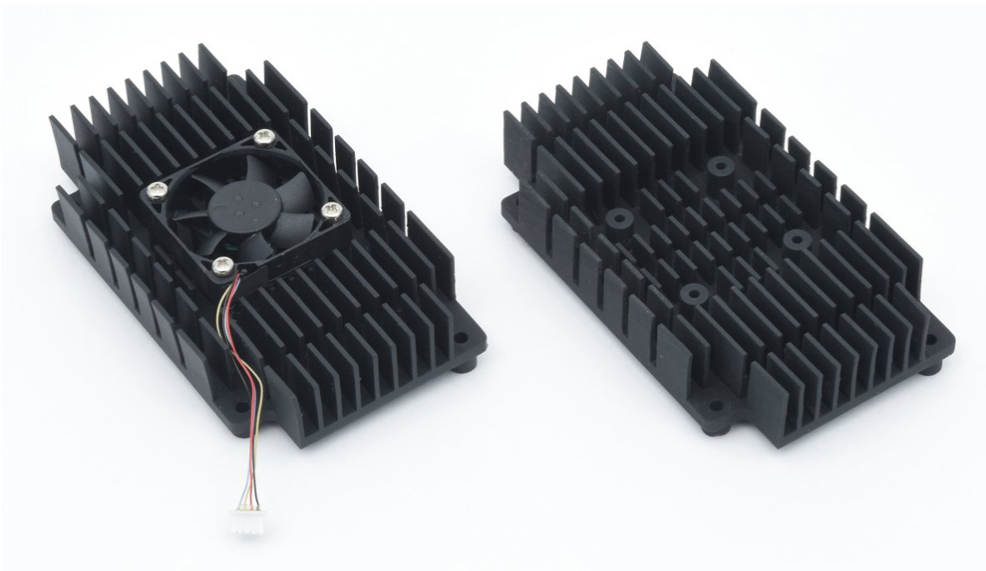

◆ Power Input

Power is provided via a barrel jack with 5.5mm OD / 2.5mm ID dimensions. The input voltage range is 10.8-25.2VDC (supports 7V +/-5% and 24V +/-5% input voltages). A minimum 30W power supply is recommended to support peak power of the carrier, Jetson module, and attached I/O devices and provide a suitable safety margin. Diamond AC adapter **PS-12V-03** provides 12V / 5A DC power with the required mating plug and an IEC 3 prong input power plug. A US AC power cord is included.

◆ Ordering Information

◆ Models and Accessories

Floyd-SC

available models:

FLDSC-BB01	Floyd SC low-cost carrier for Jetson Nano	Available
FLDSC-BB02	Floyd SC full featured carrier for Jetson NX / TX2 NX	Available
FLDSC-ASY-01-NAO	Floyd SC assembly with Jetson Nano, Fan sink, and OS installed	Available
FLDSC-ASY-02-TNX	Floyd SC assembly with Jetson TX2 NX, Fan sink, and OS installed	Available
FLDSC-ASY-02-XNX	Floyd SC assembly with Jetson Xavier NX, Fan sink, and OS installed	Available

Please [login](#) or [signup](#) for an online quote request.

Cables and accessories

available models:

PS-12V-03 AC adapter, 12V / 5A output

Please [login](#) or [signup](#) for an online quote request.

www.diamondsystems.com | Sunnyvale, California USA | [+1-650-810-2500](tel:+1-650-810-2500) | sales@diamondsystems.com