



Jackson carrier board



Jackson carrier with Orin NX and fan sink installed

FEATURES

- Carrier board and integrated assembly for NVIDIA Jetson Orin Nano / Orin NX GPU modules
- 2x Gb Ethernet with RJ-45
- 3x USB 3.2 / 1x USB 2.0 ports
- 1x RS-232/485, 1x RS-232 serial ports
- 1x HDMI 2.0a/b with audio support
- 2x 4-lane CSI camera connectors
- 16x GPIO 3.3V/5V
- 1x CAN 2.0 port
- Minicard socket with PCIe, USB, and SIM socket
- M.2 E-key 2230 socket
- M.2 M-Key 2280/2242 socket
- Daughterboard expansion connector with PCIe and USB3 links
- Compact size 4.33 x 3.35" / 110 x 85mm
- 7-20VDC Input voltage
- 25 to +80 deg. C Operation (matching Orin modules)

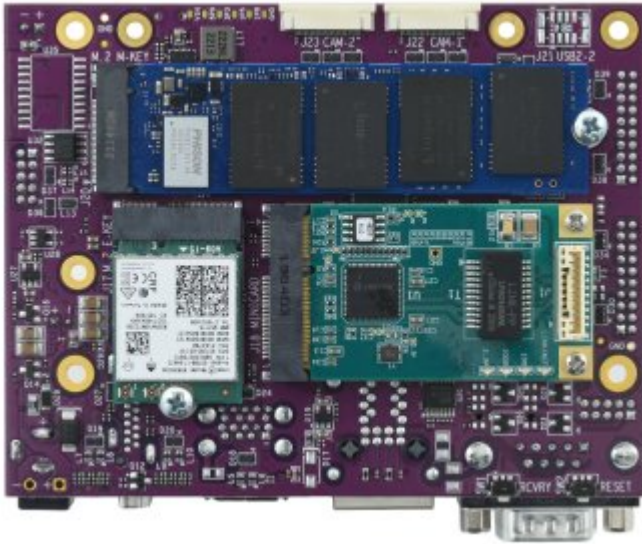

Jackson bottom view showing M.2 E key, M.2 M key, and minicard sockets

Jackson provides a compact, economical, and I/O-rich solution for NVIDIA Jetson Orin Nano / Orin NX GPU modules. Jackson brings out all I/O from the modules to I/O connectors or expansion sockets. Two quad-lane CSI camera connectors enable high-performance image processing applications utilizing the enhanced capabilities of the Orin series.

An I/O expansion connector provides a convenient way to customize Orin Nano / NX applications by designing low-cost I/O daughterboards that mount directly underneath the Jackson carrier board. The connector provides PCIe, USB3, I2C, and power via a flex circuit cable. Daughterboards can be designed to provide extra Ethernet and USB ports, extra M.2 and minicard sockets, and other I/O.

Jackson is available both as a carrier board and as a complete integrated solution with Jetson module and fan sink installed and Linux OS loaded. See the ordering information tab for part numbers and configurations.

The illustrations below show the wealth of I/O and expansion sockets available on Jackson.

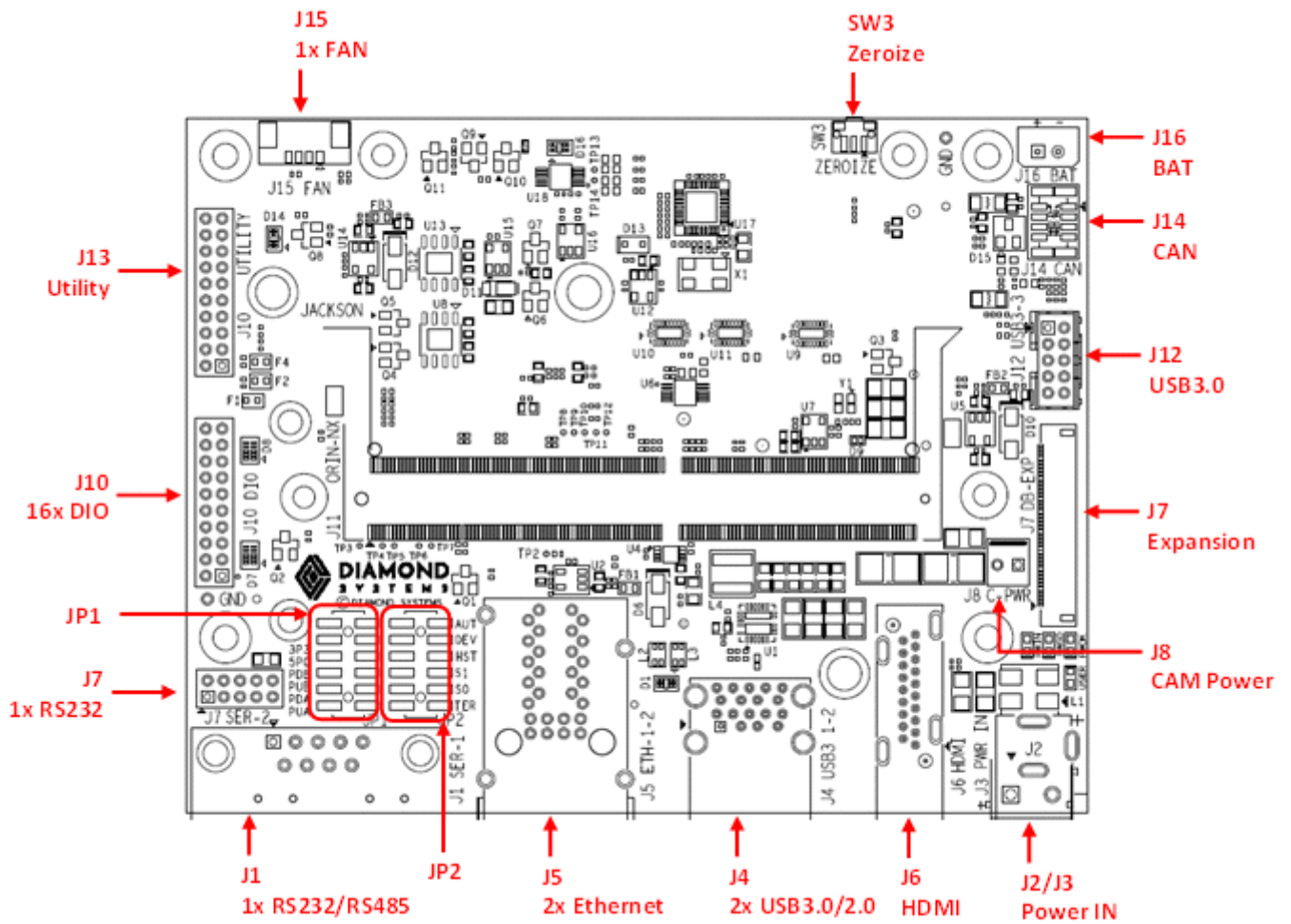

Top side features

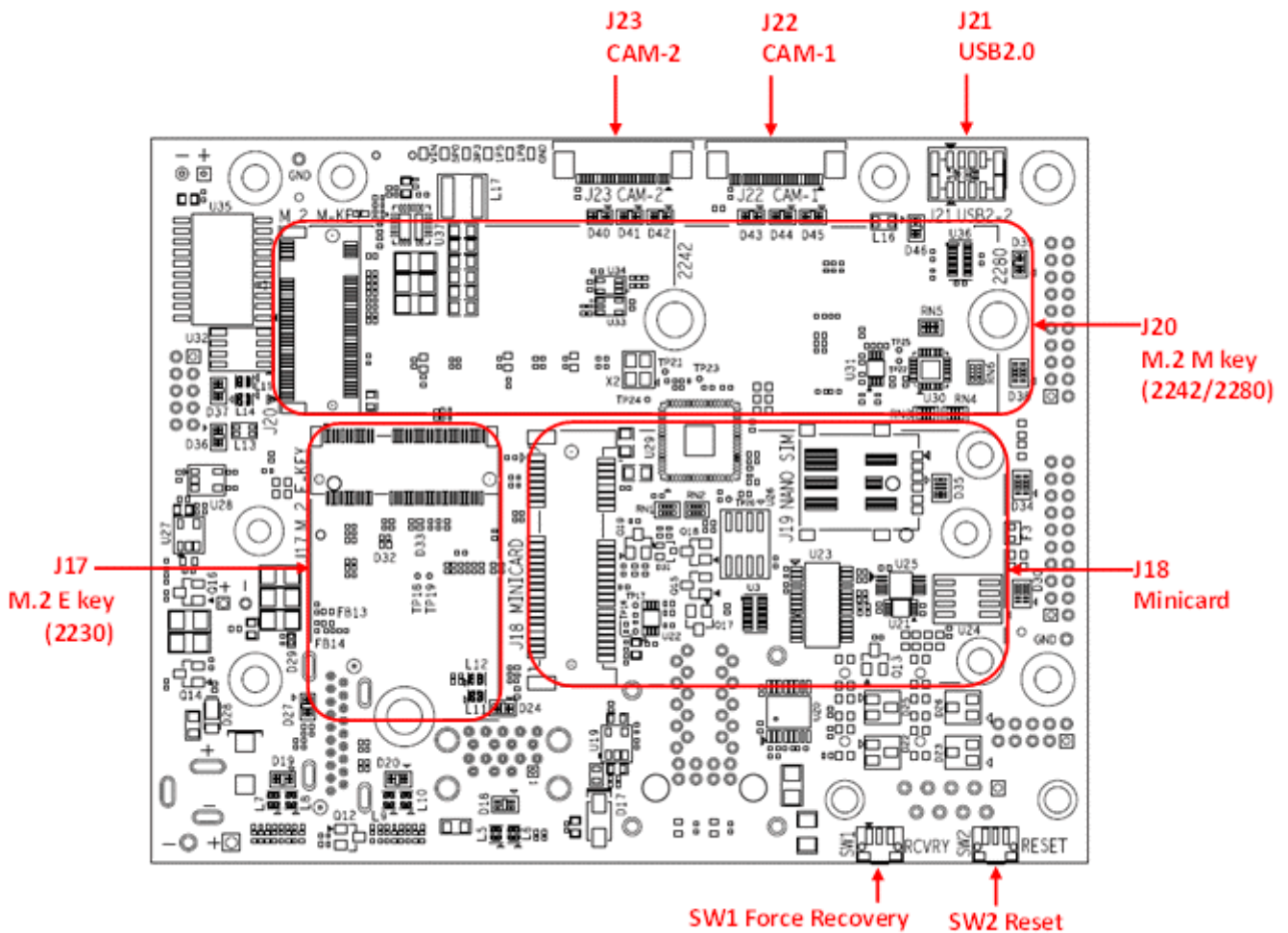

Bottom side features

◆ Expansion Capabilities

Jackson contains multiple sockets for I/O and mass storage:

- The M.2 M key socket with NVMe PCIe x4 connectivity is generally used for mass storage, since the Orin Nano and Orin NX modules lack integrated eMMC mass storage. The socket supports both 2242 and 2280 size modules, and all mounting hardware is included.
- A full-size minicard socket provides both PCIe and USB interfaces to support a wide range of I/O modules including analog, digital, serial, Ethernet, WiFi, and Bluetooth.
- An M.2 E key 2230 socket supports the installation of modem, WiFi, and Bluetooth modules for mobile applications.

Daughterboard Expansion

A unique flex cable connector enables additional I/O expansion with off the shelf or custom-developed daughterboards. The connector offers USB 3.0 and PCIe connectivity to the Jetson module, as well as power. Since an I/O daughterboard is much quicker and easier to design than a full-custom carrier board, the effort required to add custom I/O to your Orin Nano / NX project is simplified. For example, additional USB 3.0 ports, additional Ethernet ports, an Ethernet switch, or even a PoE PD circuit can all easily be implemented on a daughterboard.

Daughterboards typically are the same size as the main board and mount directly underneath the main board for convenient packaging. They can also be mounted in tandem for a thinner but wider form factor.

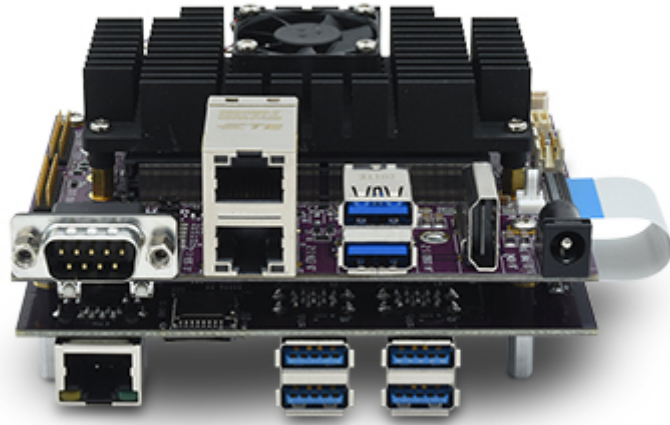

JACKSON Orin NX / Nano Carrier Block Diagram

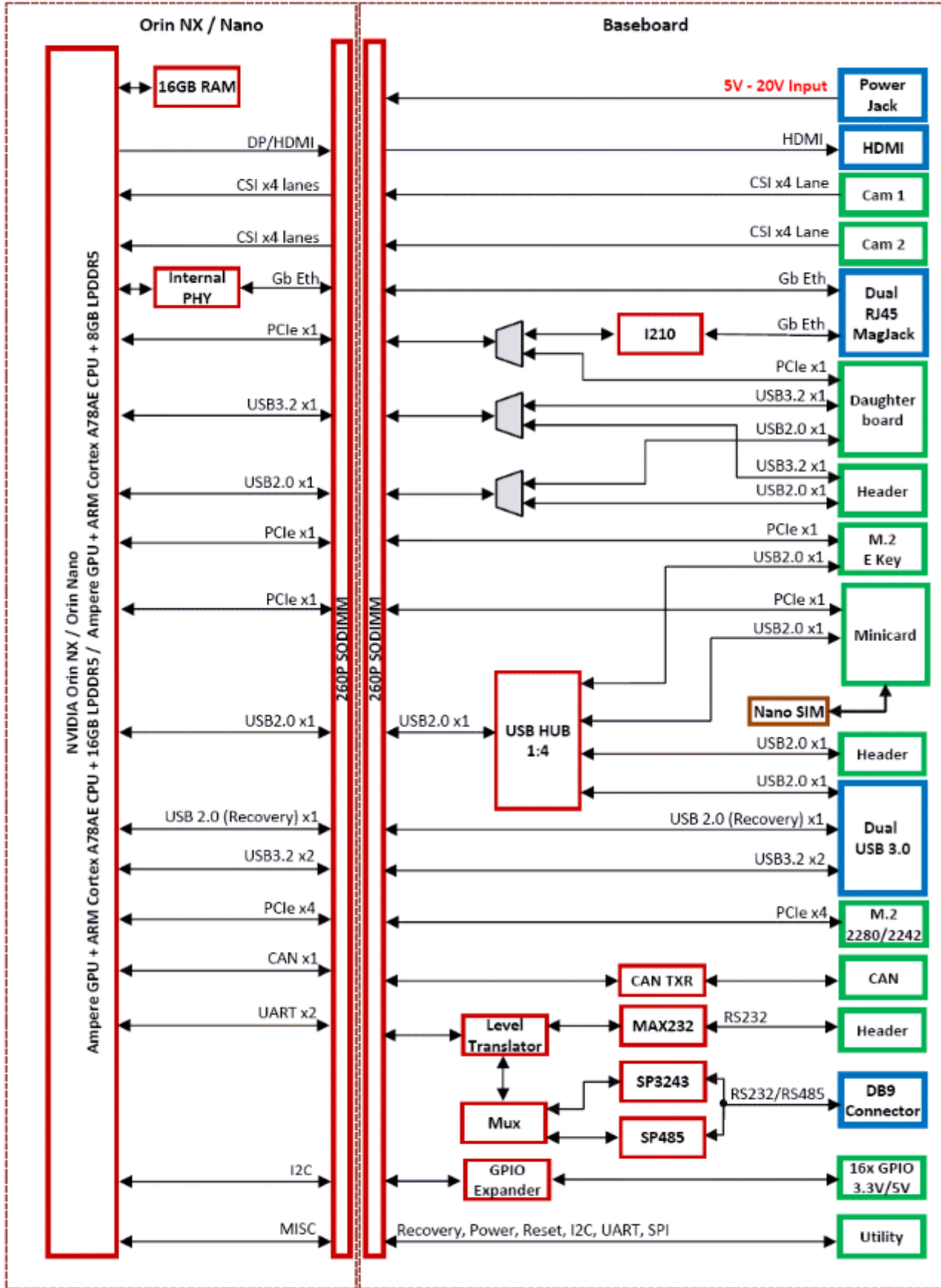

Rev 0.7

Jackson is available both as a carrier board and as a complete assembly with the Jetson module and fan sink installed. The Jetson module is preprogrammed with a full Linux OS based on the latest Nvidia JetPack release.

Models and Accessories

Jackson		
	available models:	Availability:
JAX-BB01	Jackson carrier board for NVIDIA Jetson Orin Nano & Orin NX	May 2023
JAX-ASY-ONA8	Jackson carrier board with Orin Nano 8GB installed and programmed, with fan sink	May 2023
JAX-ASY-ONX8	Jackson carrier board with Orin NX 8GB installed and programmed, with fan sink	May 2023
JAX-ASY-ONX16	Jackson carrier board with Orin NX 16GB installed and programmed, with fan sink	May 2023

www.diamondsystems.com | [Sunnyvale, California USA](#) | [+1-650-810-2500](tel:+16508102500) | sales@diamondsystems.com